

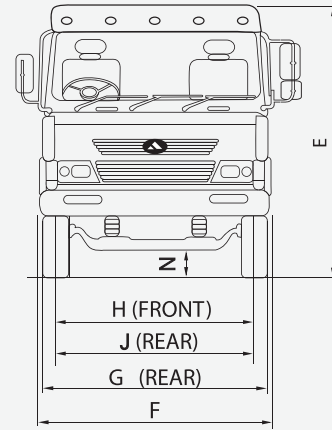

# 2523 TP

Box Body

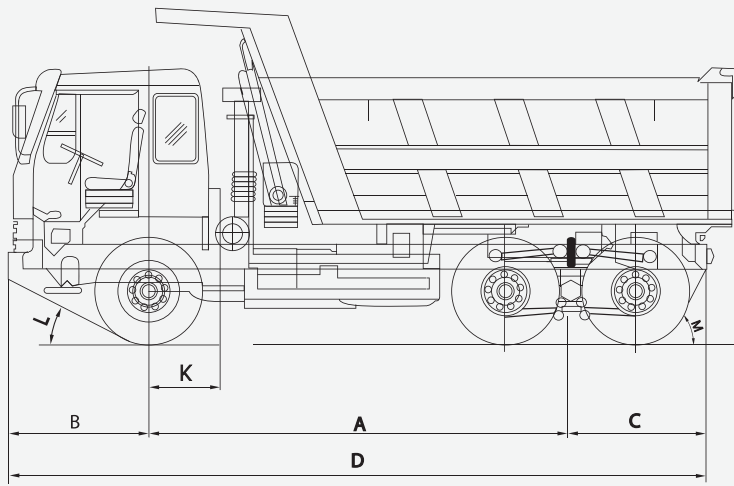



## Asia MotorWorks Ltd.

## 2523 - 4300 WB 6 x 4 TIPPER BOX

### CHASSIS NOMINAL DIMENSIONS - Unladen (mm)

|                                  |   |      |
|----------------------------------|---|------|
| A) Wheel Base                    | : | 4300 |
| B) Front Overhang                | : | 1350 |
| C) Rear Overhang                 | : | 1435 |
| D) Overall Length                | : | 7085 |
| E) Overall Height (Cab)          | : | 2700 |
| F) Overall Width (Cab)           | : | 2475 |
| G) Overall Width (Rear Tyres)    | : | 2494 |
| H) Wheel Track - Front           | : | 2020 |
| J) Wheel Track - Rear            | : | 1856 |
| K) Front Axle to Back of Cabin   | : | 760  |
| L) Approach Angle                | : | 20°  |
| M) Departure Angle               | : | 60°  |
| N) Min. Ground Clearance - Front | : | 282  |
| O) Min. Ground Clearance - Rear  | : | 270  |
| P) Frame Width                   | : | 864  |

### WEIGHTS (Kgs)

|            | Unladen chassis | Laden (CMVR) |
|------------|-----------------|--------------|
| Front Axle | : 3470          | 6000         |
| Rear Axle  | : 4210          | 19000        |
| Total      | : 7790          | 25000        |

### ENGINE

Model : CUMMINS B5.9 215HP – BSIII  
 Type : DI – Turbo Charged after Cooled Diesel Engine  
 No. of Cylinders : 6 Inline  
 Bore x Stroke : 102 x 120 mm  
 Capacity : 5883 cc  
 Max. Power : 158 KW (235 BHP) @ 2500 Rpm  
 Max. Torque : 836Nm @ 1500 Rpm  
 Compression Ratio : 18:01  
 Oil Sump Capacity : 15.4 Ltrs  
 Air Filter : Dry type Remote Mounted  
 Oil Filter : Full Flow Paper Type  
 Fuel Filter : Single filter with water separator  
 Fuel Injection Pump : Rotary FIP  
 Fuel Tank : 220 Ltrs

### CLUTCH

SETCO, Single Dry Plate Coil Spring type, Hydro Pneumatically operated.

### GEARBOX

Model : 9S 1110 2F GB: Synchronesh  
 Speed Ratios: low - 12.73  
 I – 8.83, II – 6.28, III – 4.64, IV – 3.48, V – 2.54, VI – 1.81, VII – 1.34, VIII – 1.00, Reverse – 12.04

### PROPELLER SHAFT

1710 Series: GB to R1 axle,  
 SPL90 Series - Inter axle, R1 axle to R2 axle

### REAR AXLE

Fully Floating Rear Axles with Hypoid Bevel Gears for forward rear axle & heavy duty tubular trailing dummy axle  
 Ratio: 6.72:1

### FRONT AXLE

Forged "I" Beam - Reverse Elliot type

### FRAME

BSK 46 Steel, Ladder Type Bolted Cross members.  
 Side Member: 270 x 82 x 7 mm Channel reinforced with inner channel section of 7 mm thick

### SUSPENSION

Front: Semi Elliptical leaf springs with shock absorber  
 Span: 1650 mm  
 Rear : Fully articulated inverted Semielliptical Leaf Springs on Tandem Bogie Triunion with Torque rods  
 Span: 1350 mm

### SHOCK ABSORBERS

Heavy Duty, Double-Acting Hydraulic Shock Absorbers on Front Suspension - 2 nos.

### STEERING

Integral Power Steering, with Double UJ. Ratio 20.4:1  
 Adjustable Steering Wheel  
 Steering Wheel Dia: 475 mm

### WHEELS & TYRES

Rims : B7.5 x 20 – 10 Bolts, Spigotted  
 Tyres : Front: 10.00 X 20 – 16 PR - 2 Nos (Highway)  
 Rear: 10.00 X 20 – 16 PR – 8 Nos (Lug)  
 Spare: 10.00 X 20 – 16 PR - 1 Nos (Highway)

### BRAKES

Service Brake: Dual Circuit Full Air  
 Parking Brake: Spring Actuated on Rear Axles  
 Engine Exhaust Brake: Butterfly Type, Provided

### ELECTRICAL SYSTEM

System : 24 Volts (Negative Earth)  
 Alternator : 75 Amps (A/C)  
 Battery : 2 x 12v x 130 Amp hr (20 hr rating)

### CABIN

Fully furnished, Tiltable Sleeper Cabin, A/C

### BODY & TIPPING SYSTEM

All steel welded HYVA body with automatic tailgate.  
 Capacity: 16 cu.m box & 14 cu.m rock, single ram  
 Front end tipping, Tipping angle > 48°

### PERFORMANCE (@ 25,000 Kgs)

Max. Speed - Geared (KMPH) : 78.00  
 Max. Gradeability (%) Running : 52.30  
 First gear (KMPH) : 36.00  
 Min. Turning Circle Radius-mm : 8810

Do not weld or drill chassis

Technical Specifications are subject to change without notice  
 Accessories shown are not part of the standard fitment

