

2518 HL

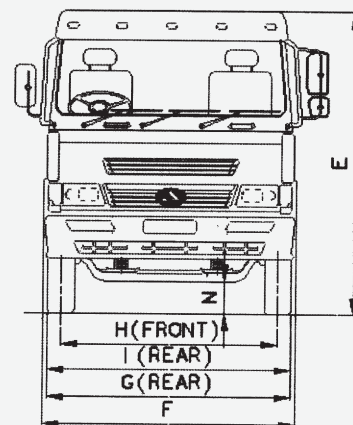

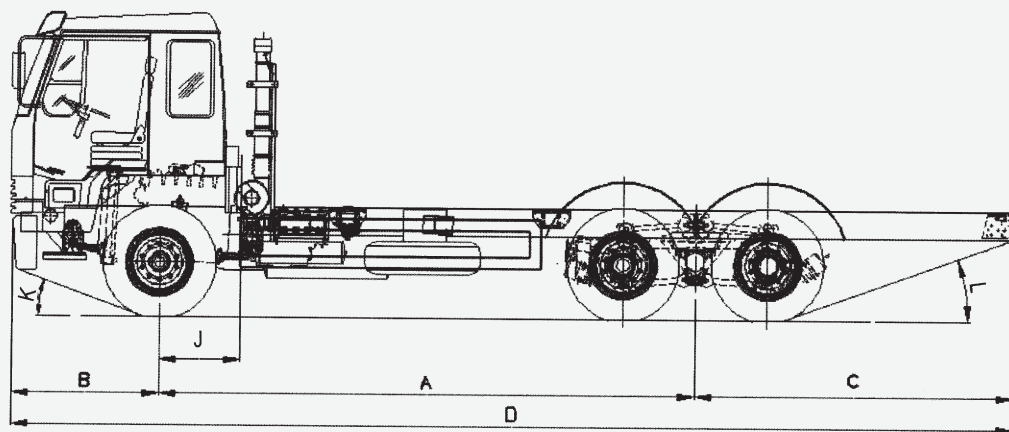

Asia MotorWorks Ltd.

2518 - 5000 WB 6 x 2 HAULAGE

CHASSIS NOMINAL DIMENSIONS - Unladen (mm)

A) Wheel Base	: 5000
B) Front Overhang	: 1295
C) Rear Overhang	: 2975
D) Overall Length	: 9325
E) Overall Height (Cab)	: 2700
F) Overall Width (Cab)	: 2475
G) Overall Width (Rear Tyres)	: 2494
H) Wheel Track - Front	: 2020
J) Wheel Track - Rear	: 1856
K) Front Axle to Back of Cabin	: 760
L) Approach Angle	: 19°
M) Departure Angle	: 18°
N) Min. Ground Clearance - Front	: 280
O) Min. Ground Clearance - Rear	: 270
P) Frame Width	: 864

WEIGHTS (Kgs)

	Unladen chassis	Laden (CMVR)
Front Axle	: 3290	6000
Rear Axle	: 3940	19000
Total	: 7230	25000

ENGINE

Model : CUMMINS – B5.918031 – BS III
 Type : DI – Turbo Charged after Cooled Diesel Engine
 No. of Cylinders : 6 Inline
 Bore x Stroke : 102 x 120 mm
 Capacity : 5883 cc
 Max. Power : 132 KW (178 BHP) @ 2500 Rpm
 Max. Torque : 675Nm @ 1500 Rpm
 Compression Ratio : 18:01
 Oil Sump Capacity : 15.4 Ltrs
 Air Filter : Dry type Remote Mounted
 Oil Filter : Full Flow Paper Type
 Fuel Filter : Single filter with water separator
 Fuel Injection Pump : Rotary FIP
 Fuel Tank : 240 Ltrs

CLUTCH

SETCO, Single Dry Plate Coil Spring type, Hydro Pneumatically operated.

GEARBOX

Model : Eaton 6306A – 6S
 Speed Ratios:
 I – 9.01, II – 5.27, III – 3.22, IV – 2.04,
 V – 1.36, VI – 1.00, Reverse – 8.36

PROPELLER SHAFT

1710 Series: GB to Rear Axle, No. of shafts: 2 (Coupling shaft and Drive shaft), SPL90 Series - Inter axle shaft

REAR AXLE

Fully Floating Rear Axles with Hypoid Bevel Gears for forward rear axle & heavy duty tubular trailing dummy axle
 Ratio: 6.17:1

FRONT AXLE

Forged "I" Beam - Reverse Elliot type

FRAME

BSK 46 Steel, Ladder Type Bolted Cross members.
 Side Member: 256 x 75 x 7 mm Channel reinforced with inner channel section of 5 mm thick

SUSPENSION

Front: Semi Elliptical leaf springs with shock absorber
 Span: 1650 mm
 Rear : Fully articulated inverted Semielliptical Leaf Springs on Tandem Bogie Triunion with Torque rods
 Span: 1350 mm

SHOCK ABSORBERS

Heavy Duty, Double-Acting Hydraulic Shock Absorbers on Front Suspension

STEERING

Integral Power Steering, with Double UJ. Ratio 20.4:1
 Adjustable Steering Wheel
 Steering Wheel Dia: 475 mm

WHEELS & TYRES

Rims : B7.5 x 20 – 10 Bolts, Spigotted
 Tyres: Front: 10.00 X 20 – 16 PR - 2 Nos (Highway)
 Rear: 10.00 X 20 – 16 PR – 8 Nos (Lug)
 Spare: 10.00 X 20 – 16 PR - 1 Nos (Highway)

BRAKES

Service Brake: Dual Circuit Full Air
 Parking Brake: Spring Actuated on Rear Axles
 Engine Exhaust Brake: Butterfly Type, Provided

ELECTRICAL SYSTEM

System : 24 Volts (Negative Earth)
 Alternator : 75 Amps (A/C)
 Battery : 2 x 12v x 130 Amp hr (20 hr rating)

CABIN

Fully furnished, Tiltable Sleeper Cabin, A/C

PERFORMANCE (@ 31,000 Kgs)

Max. Speed - Geared (KMPH) : 78.00
 Max. Gradeability (%) Running : 26.2
 First gear (KMPH) : 26.2
 Min. Turning Circle Radius-mm : 10879

Do not weld or drill chassis
 Technical Specifications are subject to change without notice
 Accessories shown are not part of the standard fitment

